

Combination

Twin encoder with two electrically separated systems

Blind hollow shaft or cone shaft

300...5000 pulses per revolution

HOG 11 G



HOG 11 G

Technical data - electrical ratings

Voltage supply	9...30 VDC 5 VDC \pm 5 %
Consumption w/o load	\leq 100 mA
Pulses per revolution	300...5000
Phase shift	90° \pm 20°
Scan ratio	40...60 %
Reference signal	Zero pulse, width 90°
Output frequency	\leq 120 kHz \leq 300 kHz (on request)
Output signals	K1, K2, K0 + inverted Error output (only EMS)
Output stages	HTL-P (power linedriver) TTL/RS422
Sensing method	Optical
Shaft insulation	2.8 kV
Transmission length	\leq 350 m at 100 kHz (HTL-P) \leq 550 m at 100 kHz (TTL)
Interference immunity	EN 61000-6-2
Emitted interference	EN 61000-6-3
Approvals	CE, UL approval / E256710

Features

- Twin encoder featuring two separate systems
- Offshore and salt water firm, high protection IP 67
- TTL output driver for cable length up to 550 m
- Very high resistance to shock and vibrations
- Hybrid bearing for extended lifetime
- Big terminal boxes, turn by 180°

Optional

- Function control with EMS
- Redundant sensing with two terminal boxes for each system

Technical data - mechanical design

Size (flange)	\varnothing 105 mm
Shaft type	\varnothing 16...20 mm (blind hollow shaft) \varnothing 17 mm (cone shaft 1:10)
Shaft loading	\leq 450 N axial \leq 600 N radial
Protection DIN EN 60529	IP 67
Operating speed	\leq 6000 rpm (mechanical)
Operating torque typ.	6 Ncm
Rotor moment of inertia	340 gcm ²
Materials	Housing: aluminium die-cast Shaft: stainless steel
Operating temperature	-40...+100 °C -25...+100 °C (>3072 pulses per revolution)
Resistance	IEC 60068-2-6 Vibration 20 g, 10-2000 Hz IEC 60068-2-27 Shock 300 g, 6 ms
Explosion protection	II 3 G Ex nA IIC T4 Gc (gas) II 3 D Ex tc IIIC T135°C Dc (dust)
Connection	2x terminal box 4x terminal box (with option M)
Weight approx.	2.9 kg, 3.3 kg (with option M)

Combination

Twin encoder with two electrically separated systems

Blind hollow shaft or cone shaft

300...5000 pulses per revolution

HOG 11 G

Part number

Incremental encoder

HOG11

	G		DN			/	DN			SR	
--	---	--	----	--	--	---	----	--	--	----	--

Shaft diameter
 16H7 Blind hollow shaft ø16 mm
 20H7 Blind hollow shaft ø20 mm
 17K Cone shaft ø17 mm (1:10)

Voltage supply / signals
 I 9...30 VDC / output circuit HTL with inverted signals
 TTL 5 VDC / output circuit TTL with inverted signals
 R 9...30 VDC / output circuit TTL with inverted signals

Pulse number - see table

Output signals
 DN K1, K2, K0

Voltage supply / signals
 I 9...30 VDC / output circuit HTL with inverted signals
 TTL 5 VDC / output circuit TTL with inverted signals
 R 9...30 VDC / output circuit TTL with inverted signals

Pulse number - see table

Output signals
 DN K1, K2, K0

Redundant sensing
 Without redundant sensing
 M With redundant sensing

EMS - Enhanced Monitoring System
 Without EMS
 .2 With EMS

Pulse number

300	1000	2048	4096
500	1024	2500	5000
512	1200	3072	

Other pulse numbers on request.

Combination

Twin encoder with two electrically separated systems

Blind hollow shaft or cone shaft

300...5000 pulses per revolution

HOG 11 G

Output signals

At positive rotating direction

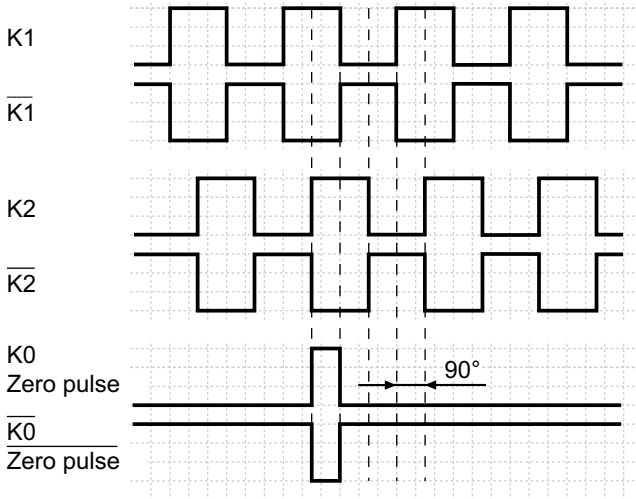

Option EMS: LED status / Error output

Flash light red*	Error of signal sequence, zero pulse or pulses (Error output = HIGH-LOW alternation)
Red	Overload output driver (Error output = LOW)
Flash light green	Encoder o.k., rotating (Error output = HIGH)
Green	Encoder o.k., stopped (Error output = HIGH)
No light	No output voltage connection or wrong connection (Error output = LOW)

* Only at rotating encoder

Accessories

Connectors and cables

HEK 8 Sensor cable for encoders

Mounting accessories

DMS 6	Torque arm size M6
11077197	Mounting kit for torque arm size M6 and earthing strap
11077087	Mounting and dismounting set

Terminal assignment

View A

Connecting terminal in terminal box

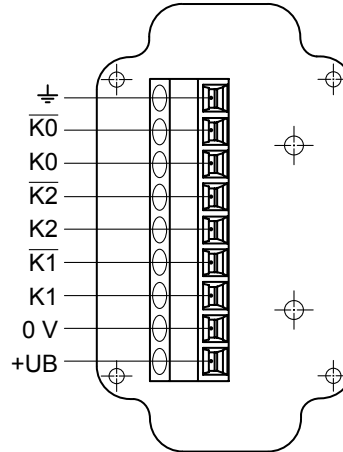

Option EMS: View A

Connecting terminal in terminal box

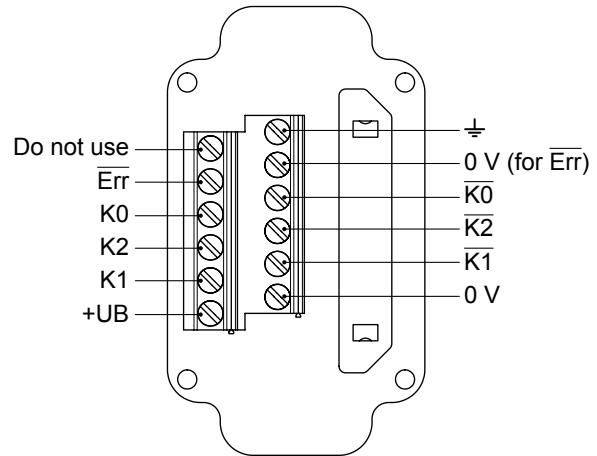

Option EMS: LED status / Error output

Flash light red*	Error of signal sequence, zero pulse or pulses (Error output = HIGH-LOW alternation)
Red	Overload output driver (Error output = LOW)
Flash light green	Encoder o.k., rotating (Error output = HIGH)
Green	Encoder o.k., stopped (Error output = HIGH)
No light	No output voltage connection or wrong connection (Error output = LOW)

* Only at rotating encoder

Combination

Twin encoder with two electrically separated systems

Blind hollow shaft or cone shaft

300...5000 pulses per revolution

HOG 11 G

Dimensions

HOG 11 G (HOG 11.2 G, HOG 11 G M, HOG 11.2 G M) - Version with blind hollow shaft

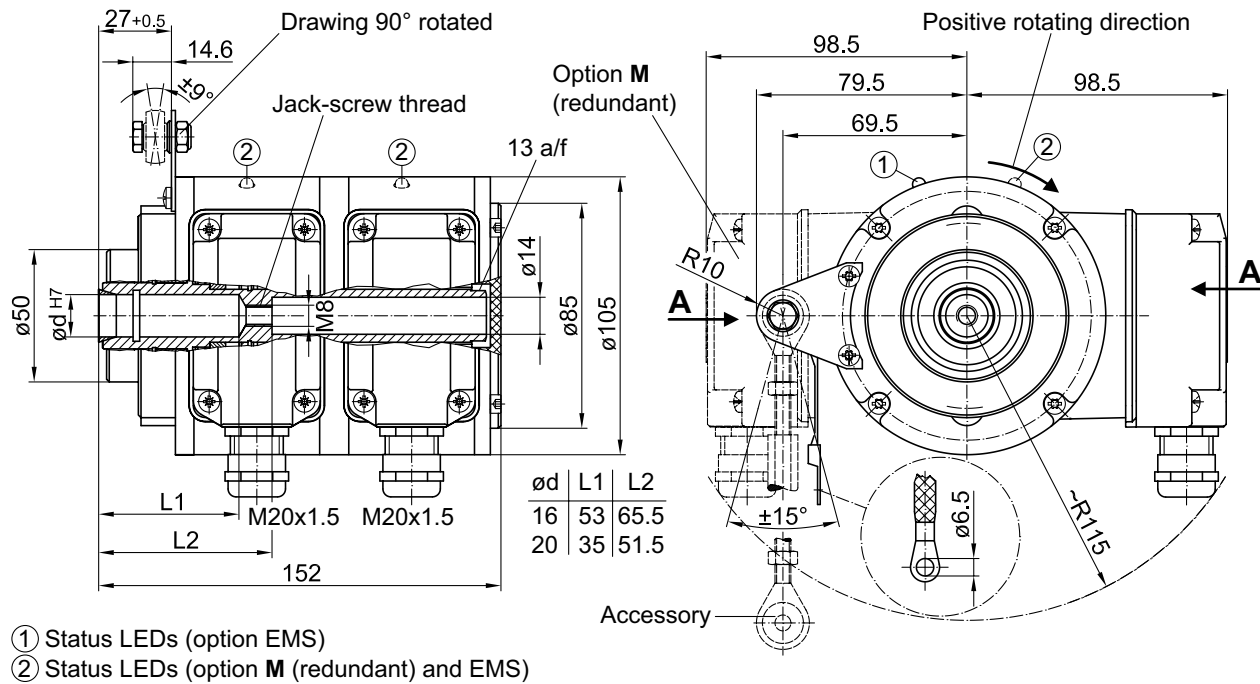

HOG 11 G (HOG 11.2 G, HOG 11 G M, HOG 11.2 G M) - Version with cone shaft

